

**REPUBLIC OF SOUTH AFRICA
DEPARTMENT OF MINERALS AND ENERGY
EXAMINATION FOR THE MINE SURVEYORS CERTIFICATE OF COMPETENCY**

DATE: 17 October 2003 (Friday)
TIME: 08:30 to 11:30 (3 Hours)

TOTAL MARKS: 100
TO PASS: 50

SURVEY II

- Note:**
- (1) Work to 1 second of arc and 0,001m.
 - (2) All steps and checks must be shown.
 - (3) Logs and functions must be shown to six (6) decimal places.
 - (4) Sketches are not drawn to scale.
 - (5) The make and model number of your calculator **must** be written on the front cover of your answer book.

QUESTION 1

PSMS p 140

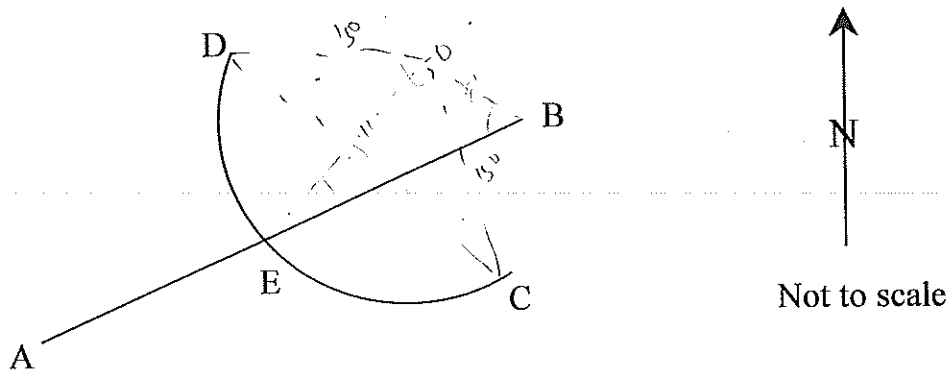

A curvilinear railway boundary CD is intersected by the farm boundary AB at E.

The radius of the curve is 150m.

Given:	Co ordinates (Metres)	
	Y	X
A	164,636	56,441
B	-69,326	-17,438
C	15,615	90,731
D	117,735	-105,413

Calculate the co ordinates of E.

97,273 35,169.

[26 marks]

QUESTION 2

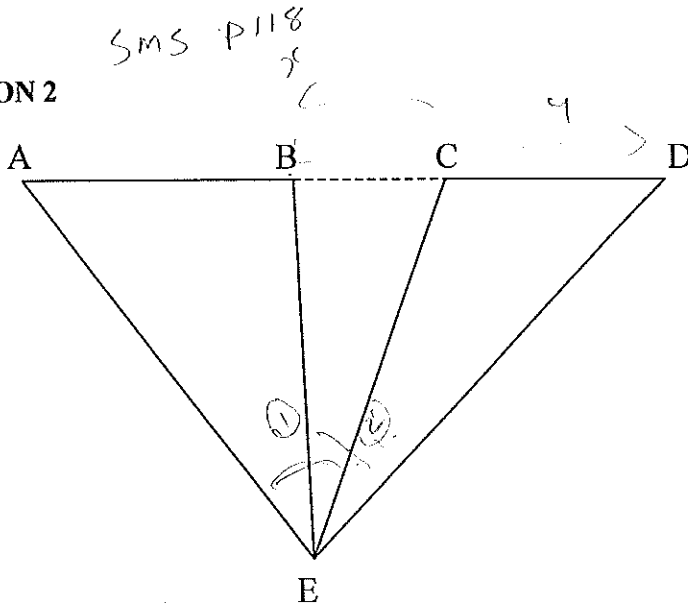

$\frac{\sin \hat{E}_1}{\sin \hat{B}_1} =$

Not to scale

AB and CD are two portions of a base line separated by the portion BC which cannot be directly measured. An instrument is set up at E, and readings are taken to A, B, C and D. (A, B, C and D are on a straight line.

- Given:
- Distance AB = 152,989m
 - Distance CD = 126,473m
 - Angle AEB = 34°09'09" ↙
 - Angle BEC = 10°46'25" ↗
 - Angle CED = 33°45'23" ↘

Calculate the distance BC.

[16 marks]

QUESTION 3

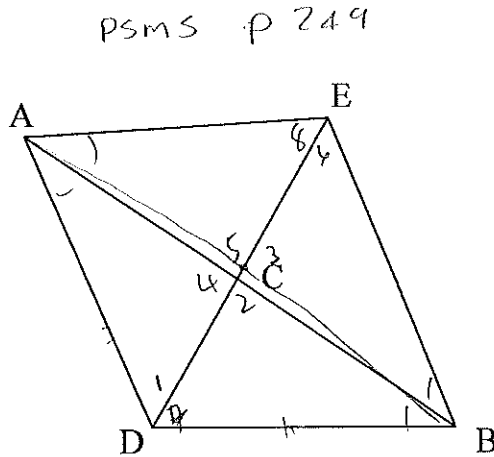

Not to scale

A and B are two main triangulation points, well built but in accessible. The co ordinates in metres being,

	Y	X
A	12 776,895	- 971,097
B	11 628,438	68,142

It is necessary to obtain the co ordinates of a further point C. The surveyor accordingly set out two further points D and E and took the following measurements.

QUESTION 3 Continued

Angle ADC = $54^{\circ}09'00''$ Angle DCA = $91^{\circ}33'50''$ Angle CDB = $58^{\circ}54'40''$
 Angle BCD = $85^{\circ}01'10''$ Angle ACE = $88^{\circ}30'10''$ Angle CEA = $58^{\circ}00'30''$
 Angle ECB = $94^{\circ}54'50''$ Angle BEC = $53^{\circ}48'00''$

On arrival at the office it was discovered that the surveyor had forgotten to take the linear measurements CD and CE as was intended, and it was not possible to return to the field.

Calculate co ordinates of C.

[19 marks]

QUESTION 4

SMS p206

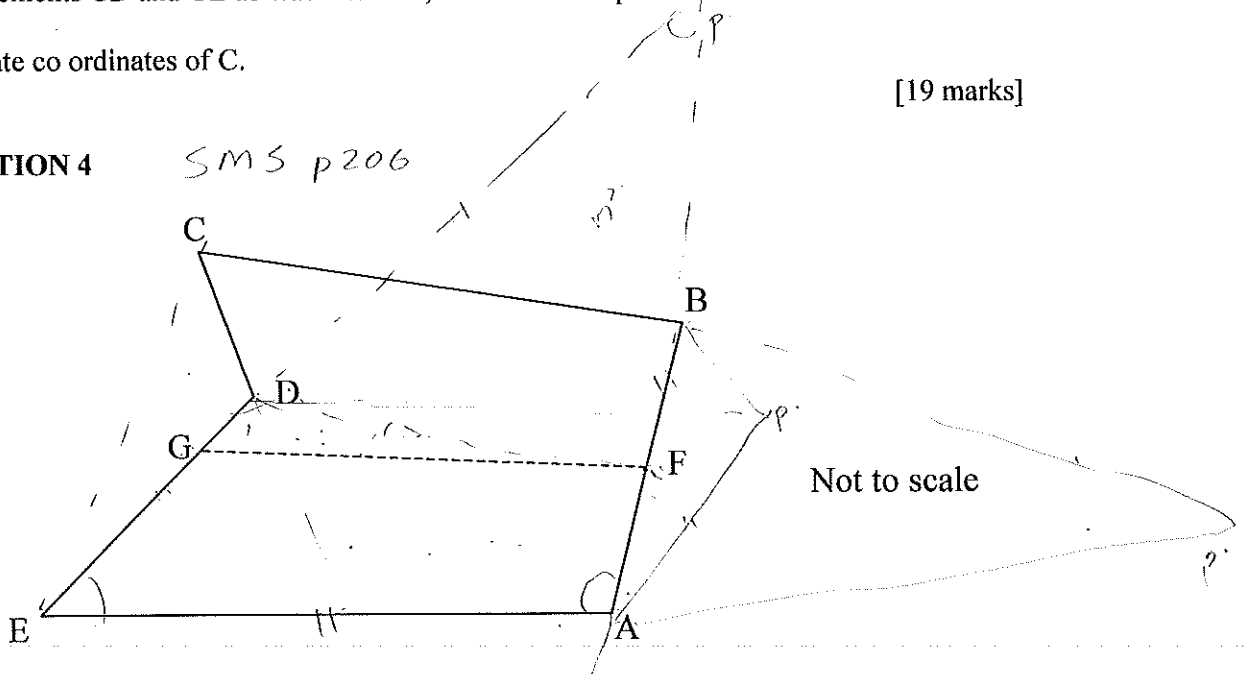

It is desired to divide the area A, B, C, D and E into two equal areas. Each having the same frontage on the line A to B, by a straight line from F (F is the centre point on the line A – B) to point G.

Given the following co ordinates,

	Y	X
A	78,000	-114,000
B	244,000	+/- 0,000
C	-33,000	131,000
D	-17,000	65,000
E	-272,000	-145,000

Calculate the co ordinates of point G on line DE.

[24 marks]

F 161 -57

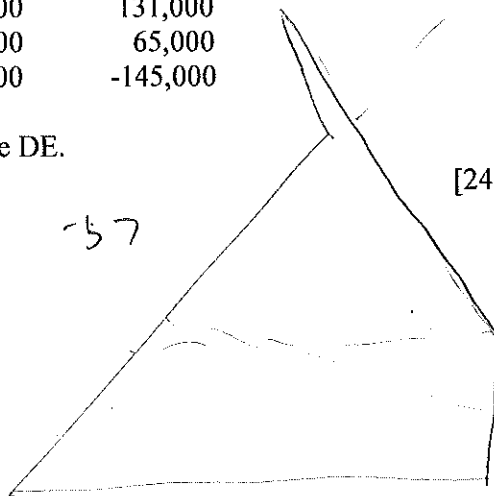

QUESTION 5

SMS p 268

A crosscut raise PAQ to a sand filling borehole passes through a faulted reef plane at A and a sand launder dipping at 10° on this reef plane has been installed on the line BC.

A launder AD dipping at 15° on the same reef plane is to connect point A (along the shortest distance on reef) with the launder BC at D. Points A and B are on the same elevation.

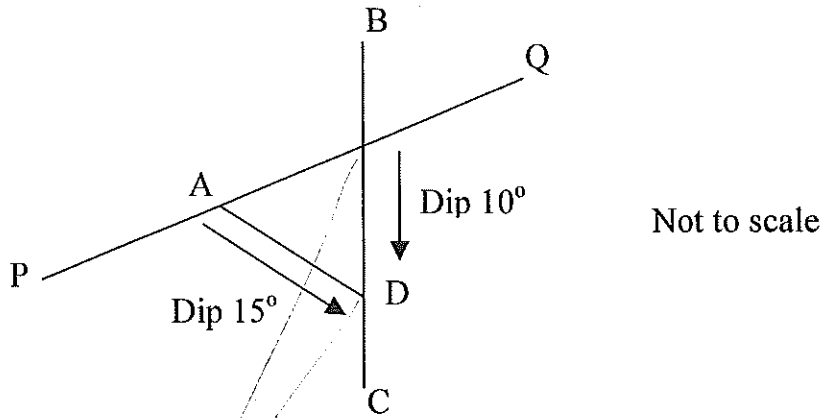

Given the following co ordinates

	Y	X
A	2 616,320	4 454,280
B	2 664,800	4 430,360
C	2 563,460	4 428,240

Calculate,

- 1 The direction and angle of True dip of the reef plane
- 2 The direction of the launder AD
- 3 The true length of the launder AD

[15 marks]

[Total 100 marks]

