

**REPUBLIC OF SOUTH AFRICA
DEPARTMENT OF MINERALS AND ENERGY
EXAMINATION FOR THE MINE SURVEYORS CERTIFICATE OF COMPETENCY**

DATE: 17 April 2009 (Friday)
TIME: 08:30 to 11:30 (3 Hours)

TOTAL MARKS: 100
TO PASS: 50

SURVEY II

- Note:**
- (1) Work to 1 second of arc and 0.001m.
 - (2) All steps and checks must be shown.
 - (3) Logs and functions must be shown to six (6) decimal places.
 - (4) Sketches are not drawn to scale.
 - (5) The make and model number of your calculator **must** be written on the front cover of your answer book.

QUESTION 1

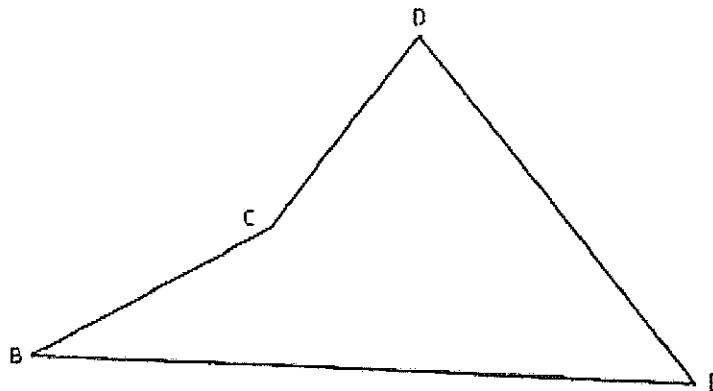

The Area of figure BCDE is 46 850,00m²

From the information given in the table below you are requested to fill in the missing data.

Angles	Sides	Co-ordinates	
		Y	X
B = 16:29:10	BC missing	B) +330,000	+370,000
C = 210:35:50	CD missing	C) missing	
D = 43:15:20	DE missing	D) missing	
E = 89:39:40		E) +490,000	-70,000

[23 marks]

QUESTION 2

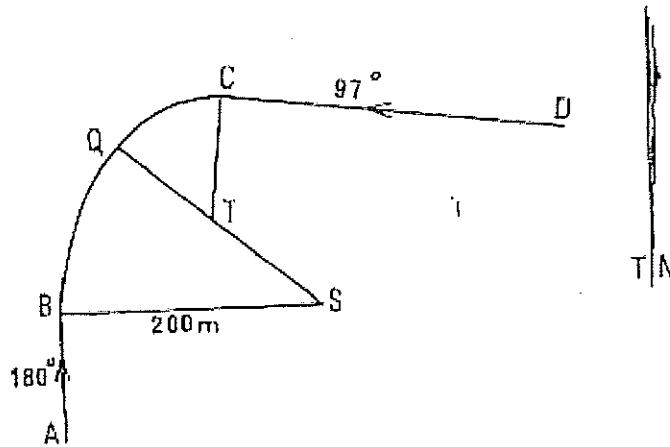

AB and CB are the centre lines of two straight stretches of a railway which are to be connected by means of a double curve BQC. BQ is the one and QC the other circular curve.

Given:

Co-ordinates		Directions
B	$\pm 0,000 \quad \pm 0,000$	AB = $180^{\circ}00'00''$
C	$- 140,000 \quad - 166,667$	DC = $97^{\circ}00'00''$
Radius of curve BQ is 200 metres		

Calculate:

1. The co-ordinates of Q
2. The radius of the circular curve QC (i.e. the length of TC)
3. The co-ordinates of T, the centre of the circular curve QC.
4. The total length of the curve BQC.

[24 marks]

QUESTION 3

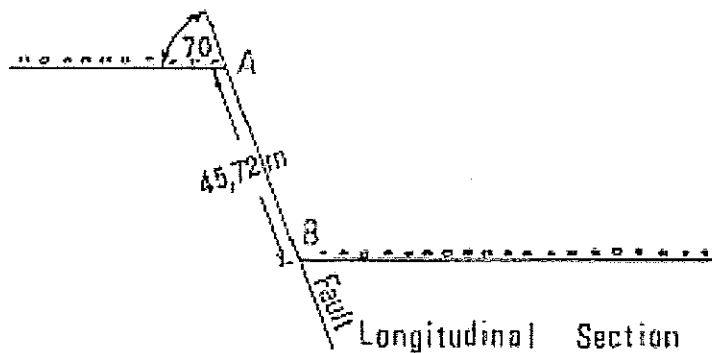

The above sketch is a longitudinal section of reef-fault dislocation, the section being drawn parallel to the strike of the reef, which is due East and West.

The strike of the fault is N 30° E by S 30° W, and the dip of the reef is 35° South.

The reef is thrown down to the East, a distance AB equal to 45,72 metres along the fault, which dips at 70° in the direction of the section.

Calculate:

1. The distance from A of a level crosscut along the fault to reef on the East side of the fault.
2. The true dip of the fault.
3. The direction of the line of intersection of the reef and the fault.

[16 marks]

QUESTION 4

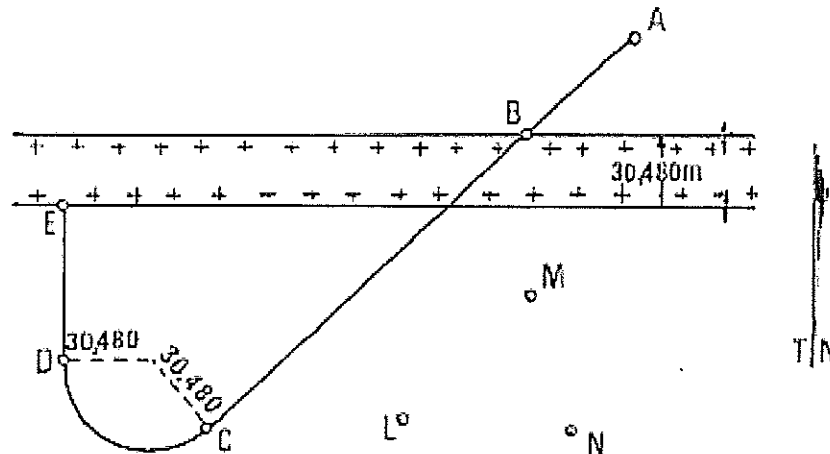

A and B are stations on the footwall of an inclined haulage in the course of sinking on a reef plane which dips in a southerly direction. AB is the centre line of the tracks which are graded at -15° .

A vertical dyke, striking due east and west, was encountered at B. From B three boreholes were drilled down through the dyke striking the reef plane at L, M and N.

It was found that there was no change in either the direction of strike or dip of this reef plane, and that the actual thickness of the dyke was 30,480 metres. It was decided to continue sinking the inclined haulage AB without change of dip or direction to a point C where a circular haulage of 30,480 metres radius would be driven on a level grade to end at D, from which point the sinking of the -15° haulage would continue and end at E on the reef dyke intersection on the south side of the dyke.

The direction DE to be at right angles to the strike of the dyke.

Given:

	Co-ordinates (metres)		Elevation at Reef Plane (metres A.M.S.L.)
	Y	X	
L	+ 353,620	+ 649,119	1 431,766
M	+ 307,424	+ 598,868	1 450,056
N	+ 282,090	+ 649,119	1 431,766
B	+ 307,424	+ 537,908	1 516,616

Calculate:

1. The direction of the line ML.
2. The dip of the reef in the direction ML.
3. The co-ordinates of points C, D and E.

[26 marks]

QUESTION 5

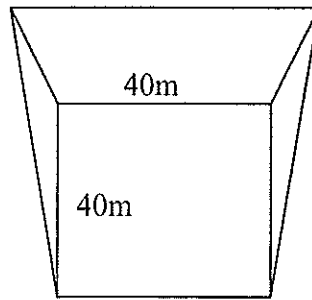

Not to
Scale

A building site is to be excavated on a hill sloping at 10° to the horizontal. If the horizontal base of the site is to be 40 metres by 40 metres and the sides of the excavation are to slope at 1 metre vertical to 1,5 metres horizontal.

Calculate the volume of the earth to be excavated.

[11 marks]

Total [100 marks]